



Typical Specifications For DynaFlame Domestic Hot Water Supply – Non-Condensing Models DF(N,P)W 0500– 6004

The domestic hot water boiler shall be a CAMUS DYNAFLAME model _____ having a recovery capacity of _____ gph (lph) at 100° F (56° C) rise for DHW.

The domestic hot water boiler shall be design certified by CSA International and shall meet the requirements of ANSI Z21.10, and CSA 4.3. The domestic hot water boiler shall be vented as a Category I or III non-condensing appliance.

Performance Overview:

- Boiler shall operate up to 85% thermal efficiency
- Heat exchanger shall be cylindrical 16 tube (Models 500 – 1200), 28 tube (Models 1500 – 4000), 32 tube (Models 4500 – 5000), 40 tube (Models 4504 – 6004) C12200 copper alloy with cast bronze headers and all gasket-less sealed design, optional C70600 cupronickel alloy is available
- Fine tuned combustion premix providing homogeneous air and gas combustion mix to a radial burner incorporating a knitted stainless steel wrap ensuring stable light off and efficient clean combustion.
- 3:1 gas input turn down ratio with sustained efficient combustion characteristics throughout entire modulating range
- Oxides of Nitrogen (NOx) of 9 ppm corrected to 3% oxygen.
- Category I venting certification with Category I and Category III available
- The boiler is fully factory fire tested to obtain optimum combustion characteristics and to establish certified gas input rates.
- System safety and operating devices and controls are fully configured, calibrated and factory tested.
- Models consist of an input range of 500 MBTUH to 6000 MBTUH
- The boiler shall comply with the energy efficiency requirements of the latest edition of the ASHRAE 90.1 Standard

Combustion Chamber:

The combustion chamber shall be constructed of stainless steel, sealed water tight, chamber to be covered with minimal ¼" thick ceramic insulation. A stainless steel access door shall be provided for ease of service and inspection to the outer heat exchanger surface and an easily removable radial fired knitted fiber stainless steel burner to access the internal combustion chamber for inspection, service, and cleaning. A window view port shall be provided for visual inspection of the boiler combustion during firing.

Heat Exchanger:

The heat exchanger shall be tested and inspected to A.S.M.E. Section IV requirements. The A.S.M.E. Section IV seal of approval will not be provided as standard for jurisdictions not requiring the A.S.M.E Section IV seal of approval. The heat exchanger shall be a four pass design with a maximum working pressure of 160psig (1100kPa). The heat exchanger is of cylindrical design, with integral copper finned tube ⅞" I.D., 0.064" minimum wall thickness, 7 fins per inch, with nominal fin height of ⅞". Each end of the tubes shall be expanded by mechanical rolling process into the headers. The heat exchanger shall be gasket-less. All header castings shall be bronze. The heat exchanger tubes shall be copper alloy C12200 with optional cupronickel alloy C70600 available.

Gas Train:

The gas train shall consist of a pressure regulating electro-hydraulic proportional air/gas main gas actuator providing a slow opening, fast closing shutoff valve and proportional 1:1 air/gas ratio control, a fast closing safety shutoff gas solenoid, and a low gas pressure switch. Optional high gas pressure switch is available. A factory pre-set combination metering valve and orifice shall be provided for setting combustion parameters. Models DF 500 – DF 6004 operate with a 3:1 turndown ratio.

Burner/Combustion:

The combustion air fan draws gas under negative pressure and mixes it with air to generate a fine tuned air gas mixture which is delivered under positive pressure to the radial knitted stainless steel burner. Combustion modulation is established by a variable frequency drive on all models. The burner shall be a 100% stainless steel vertical mounted radial fired type with stainless knitted metal fiber construction. The burner shall combust a precise amount of premixed combustion air and gas to provide equal distribution of heat for heat transfer throughout the entire heat exchanger. Combustion products are exhausted under minimum back pressure. Combustion operates with a 3:1 turn down ratio while sustaining combustion characteristics throughout the entire modulating range. Operation of up to 85% thermal efficiency and shall be certified for Oxides of Nitrogen (NOx) of 9 ppm corrected to 3% oxygen.

Firing Mode:

The burner combustion shall operate as proportional modulating with a 3:1 turndown ratio with a minimum 35% firing rate. Light off shall be at no more than 50% to ensure a rumble free soft start.

Controls:

Standard controls include a Smartflame electronic proportional integrated combination ignition limit/operator control accurate to 1° F (0.5°C) having a 4-20 mA output signal suitable for control of a variable frequency motor drive. Control shall be capable of accepting a 0-10VDC signal for remote set point and outdoor reset operation, and have contacts for remote enable/disable of call for heat signal. Optional contacts for remote modulation signal shall accept either a 4-20mA or 0-10VDC. The control shall also provide readouts of boiler target, differential and inlet/outlet temperatures, modulation rate as well as accumulated runtime. On/off switch, and full diagnostic light package shall be provided. The complete control package shall be mounted on the front panel with hinged door for easy access to all control modules. A flow switch shall be provided loose.



Typical Specifications For DynaFlame Domestic Hot Water Supply – Non-Condensing Models DF(N,P)W 0500– 6004

Ignition Module:

The ignition module shall employ a proved igniter with 3 tries for ignition followed by a lockout condition for all models. Trial for ignition shall be 5 seconds with 15 seconds between retries. Ignition control shall include times for pre-purge, pre-ignition, ignition, and post purge.

Venting Options:

The following venting options shall be utilized:

- Category I Venting – single or combined vent
- Category III Outside Air (Horizontal & Vertical)
- Category III Through-wall Venting (Horizontal & Vertical)
- Outdoor Venting
- Category I & III Direct Venting

The following Category I vent material shall be utilized:

- 'B' type or 'C' type
- Stainless steel single-wall, where field conditions are likely to result in condensation in the vent

The following Category III vent material shall be utilized:

- Stainless or AL29-4C material, single or double wall, positive pressure rated

External Jacket and Fasteners:

The external jacket shall be of 430 stainless steel mirror finish panels and a powder paint coated access top cover assembled utilizing interference fit locks and minimal non-strip self tap screws for ease of removal and access to the heat exchanger and combustion air / gas control.



Typical Specifications For DynaFlame Domestic Hot Water Supply – Non-Condensing Models DF(N,P)W 0500– 6004

Engineer: _____

Job Location: _____

Date: _____

Prepared by: _____

Buyer's Name: _____

Quote #: _____

Job Name: _____

Buyer's Address: _____

Input & Output (MBTUH)

DYNAFLAME 0500 – 1200

Model	Non-Condensing	
	Input	Output
0500	500	425
0750	750	638
1100	1100	935
1200	1200	1020
1500	1500	1275
1750	1750	1488
2000	2000	1700
2500	2500	2125
3000	3000	2550
3500	3500	2975
4000	4000	3400
4500	4500	3825
5000	5000	4250
4504	4500	3825
5004	5000	4250
6004	6000	5100

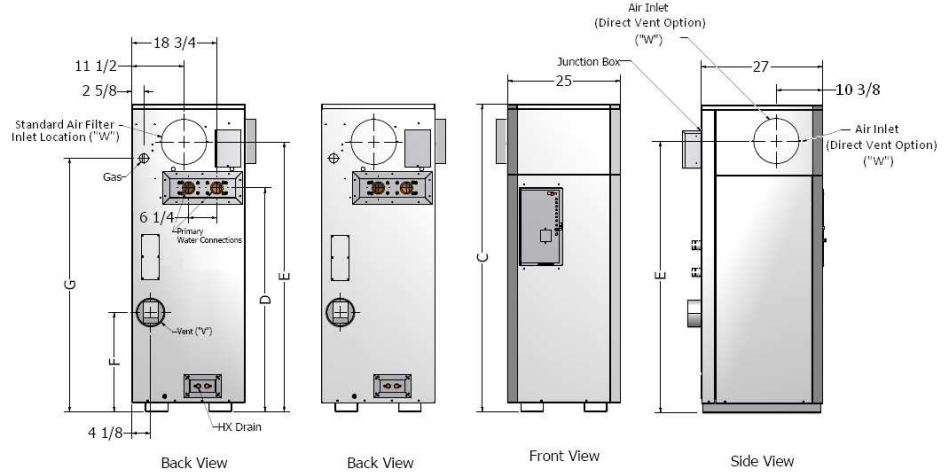

DYNAFLAME 1500 – 5000

Shipping Weight

Model	Non-Condensing
0500	375
0750	400
1100	480
1200	485
1500	578
1750	695
2000	775
2500	875
3000	920
3500	1030
4000	1140
4500	1250
5000	1350
4504	1185
5004	1533
6004	1863

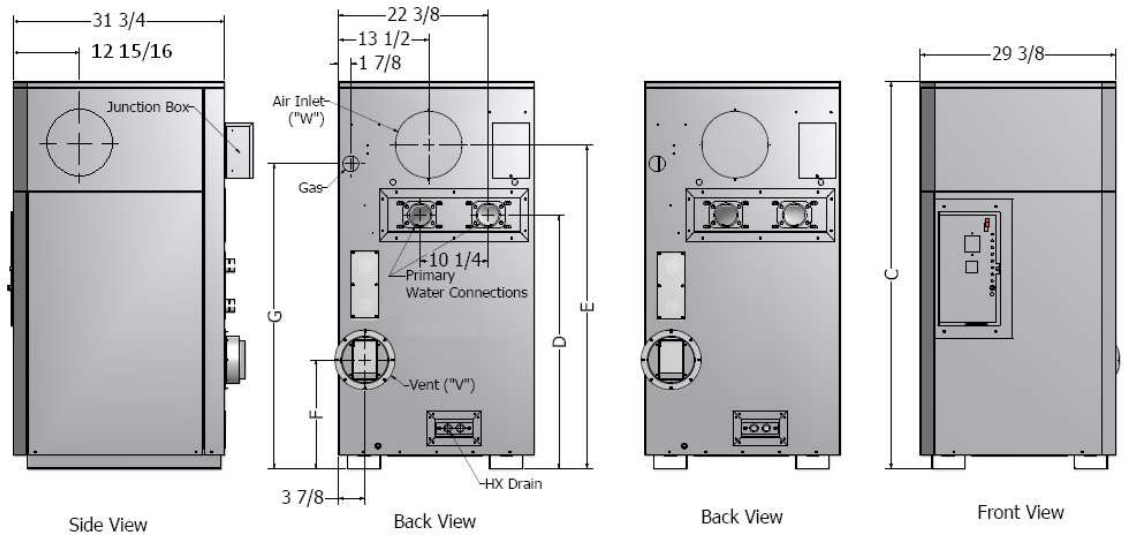

DYNAFLAME MEGA 4504– 6004

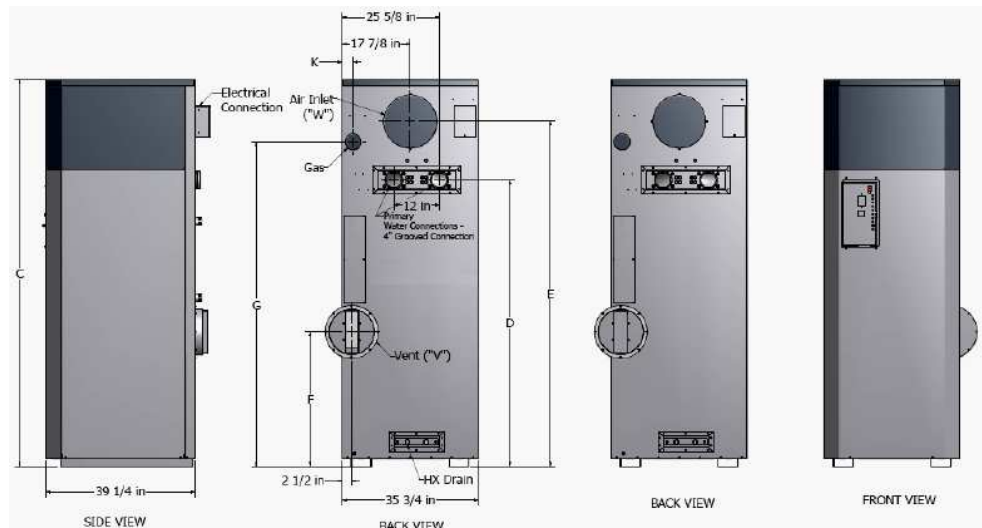



Typical Specifications For DynaFlame
Domestic Hot Water Supply – Non-Condensing
Models DF(N,P)W 0500– 6004

Dimensions

Model	Height Dim. "C" [in.]	Water Conn. "D" [in.]	Air Inlet "E" [in.]	Flue Height "F" [in.]	Gas Height "G" [in.]	Air Inlet Dia. "W" [in.]	Water Conn. Prim. [NPT, in.]*	Gas Conn. [NPT, in.]	"K"
0500	45 5/8	27	37 1/4	13 1/4	33 5/8	6	2	1	--
0750	55	36 3/8	46 5/8	15 3/4	43	8	2	1	--
1100	68 1/4	49 5/8	59 7/8	22	56 1/4	8	2	1	--
1200	68 1/4	49 5/8	59 7/8	22	56 1/4	8	2	1	--
1500	58 1/8	38 1/4	48 5/8	16 3/8	45 7/8	10	2 1/2	1 1/4	--
1750	62 5/8	42 5/8	53 1/8	16 3/8	50 3/8	10	2 1/2	1 1/4	--
2000	66 7/8	46 7/8	57 3/8	20	53 5/8	12	3	1 1/4	--
2500	73 1/2	52 5/8	63 5/8	25 3/4	60 3/8	12	3	1 1/2	--
3000	79 1/2	58 5/8	69 5/8	31 3/4	66 3/8	12	3	1 1/2	--
3500	86 1/2	63 5/8	76	24 7/8	72 5/8	14	4	2	--
4000	91 1/2	68 5/8	81	29 7/8	77 5/8	14	4	2	--
4500	96 1/2	73 5/8	86	34 7/8	82 5/8	14	4	2 1/2	--
5000	101 1/2	78 5/8	91	39 7/8	87 5/8	14	4	2 1/2	--
4504	83	59 3/4	72 1/4	20 3/4	67 7/8	14	4 (Grooved)	2 1/2	3 1/2
5004	88 1/4	65	77 1/2	26	72 1/4	14	4 (Grooved)	2 1/2	3 1/2
6004	102	75 1/2	91	35 1/2	85 1/2	14	4 (Grooved)	3	2 3/4

*For Models 1500 – 5000 Appliance Inlet/Outlet Connections are 3" NPT

Recovery Capacity

Model	100°F Rise	56°C Rise	80°F Rise	44°C Rise	60°F Rise	33°C Rise
	GPH	LPH	GPH	LPH	GPH	LPH
0500	509	1928	637	2410	849	3213
0750	764	2891	955	3614	1273	4819
1100	1120	4241	1401	5301	1867	7068
1200	1222	4626	1528	5783	2037	7711
1500	1528	5783	1910	7229	2546	9638
1750	1783	6747	2228	8433	2971	11245
2000	2037	7711	2546	9638	3395	12851
2500	2546	9638	3183	12048	4244	16064
3000	3056	11566	3820	14457	5093	19277
3500	3565	13494	4456	16867	5942	22489
4000	4074	15421	5093	19277	6790	25702
4500	4584	17350	5730	21686	7640	28915
5000	5093	19277	6366	24096	8488	32128
4504	4584	17350	5730	21688	7640	28917
5004	5093	19277	6366	24096	8488	32128
6004	6076	22998	7595	28747	10127	38330

Primary Heat Exchanger Head Loss & Flow

Model	Temperature Rise Across Heat Exchanger			
	30°F		35°F	
	USGPM	ΔP-Ft.	USGPM	ΔP-Ft.
0500	28.0	0.7	24.0	0.5
0750	42.0	1.4	36.0	1.
1100	61.6	2.7	52.8	2.1
1200	68.0	2.9	58.3	2.2
1500	83.9	1.9	71.9	1.4
1750	97.9	2.9	83.9	2.2
2000	111.9	4.1	95.9	3.1
2500	139.9	6.1	119.9	4.6
3000	167.9	8.4	143.9	7.0
3500	198.1	12.7	169.8	9.5
4000	226.9	17.0	194.5	12.7
4500	254.7	21.9	218.3	16.4
5000	282.9	27.6	242.5	20.7
4504	254.7	15.3	218.3	11.4
5004	282.9	19.6	242.5	14.9
6004	339.5	31.8	291.0	24.1

Non-Condensing Venting

Model	Vent ("V") Diameter Inches			
	Outdoor	Cat. III Up to 50 ft	Cat. III Up to 100 ft	Cat. I
0500	4	4	6	8
0750	6	6	8	10
1100	6	6	8	10
1200	6	6	8	10
1500	7	7	10	12
1750	7	7	10	12
2000	8	8	12	14
2500	8	8	12	14
3000	8	8	12	14
3500	9	9	14	16
4000	9	9	14	16
4500	10	10	14	16
5000	10	10	14	16
4524	10	10	14	16
5004	10	10	14	16
6004	12	12	14	16

Current drawn by Boiler @ 115 Volts Single Phase 60 Hz

Model	Max Amps Draw - Boiler Only
0500	7
0750	7
1100	7
1200	7
1500	11
1750	11
2000	11
2500	14

Current drawn by Boiler @ 230 Volts Phase 60Hz

Model	Max Amps Draw - Boiler Only	Phase
3000	14	Single
3500	16	Single
4000	16	Single
4500	24	Single
5000	18	Three
4504	24	Single
5004	18	Three
6004	18	Three

Model # _____ # Of Units _____ Type of Gas _____
 Total Input _____ BTU/hr Flow _____ USGPM @ Allowable Pressure Drop _____ ft.
 Total Output _____ BTU/hr
 Optional Accessories _____