



**Typical Specifications For DynaFlame Mega
Domestic Hot Water Supply
(DFX Series)
Models DF(N),(P)W 4514 - 6014**

The domestic hot water boiler shall be a CAMUS DYNAFLAME MEGA model _____ having a recovery capacity of _____ gph (lph) at 100°F (56°C) for DHW.

The domestic hot water boiler shall be design certified by CSA International and shall meet the requirements of ANSI Z21.10 and CSA 4.3. The domestic hot water boiler shall be vented as a Category I non-condensing appliance or Category II condensing appliance.

Combustion Chamber:

The combustion chamber shall be fully enclosed by a stainless steel chamber inside of which is assembled a cylindrical copper-nickel coil Heat Exchanger having a maximum allowable working pressure of 160 psig (1100 kPa). An access door shall be provided for ease of service and inspection of the Heat Exchanger.

Burner:

The burner shall be constructed of stainless steel. The burner shall provide equal distribution of heat through the entire heat exchanger. A window view port shall be provided for visual inspection of the boiler during firing.

Heat Exchanger:

The heat exchanger shall be inspected and tested to A.S.M.E. Section IV requirements. The A.S.M.E. Section IV seal of approval will not be provided as standard for jurisdictions not requiring the A.S.M.E. Section IV seal of approval. The heat exchanger shall be a four-pass heat exchanger with maximum working pressure of 160 psig (1100 kPa). The heat exchanger is of cylindrical design, with integral copper-nickel finned tube 7/8" I.D., 0.063" minimum wall thickness, 7 fins per inch, with nominal fin height of 3/8". Each end of the tubes shall be expanded by mechanical rolling process into the headers. The heat exchanger shall be gasket-less. All header castings shall be bronze. A pressure relief valve of _____ lb/hr shall be furnished with the heater.

Controls:

Standard controls include an electronic proportional integrated combination limit/operator control accurate to 1°F (0.5°C) having a 4-20 mA output signal suitable for control of a variable frequency motor drive. The control shall also provide readouts of boiler target, differential and inlet/outlet temperatures as well as accumulated runtime. On/off switch, and full diagnostic light package shall be provided. The complete control package shall be mounted on the front panel with hinged door for easy access to all control modules. A flow switch shall be provided loose.

Firing Mode:

The burner shall operate as fully modulating down to 20% of the heating load. Light off shall be at no more than 50% input to assure rattle free soft start.

Venting Options

The following venting options shall be utilized: 1. Combined Venting. 2. Horizontal & Vertical Outside air Venting. 3. Through-Wall Venting. 4. Outdoor Venting. 5. Direct Venting.

Gas Train:

The gas train shall consist of a gas valve with a pressure regulating electro-hydraulic actuator to provide slow opening, fast closing, safety shutoff and air/gas ratio control. A factory pre-set combination metering valve and orifice shall be provided for setting combustion parameters.

Ignition Module:

The ignition module shall employ a proved igniter with 3 tries for ignition followed by lockout. Trial for ignition shall proceed with 15 seconds between retrials.

External Jacket and Fasteners:

The external jacket shall be of stainless steel mirror finish panels assembled utilizing interference fit locks and minimal non-strip self tap screws.

SUBMITTAL DATA SHEET

DYNAFLAME MEGA (DHW) 4514-6014 (DFX Series)

Engineer: _____ Job Location: _____ Date: _____
 Prepared by: _____ Buyer's Name: _____ Quote #: _____
 Job Name: _____ Buyer's Address: _____

Input & Output (MBTUH)

Model	Non Condensing	
	Max Input Mbtuh	Max Output Mbtuh
4514	4500	3960
5014	5000	4400
6014	6000	5280

Shipping Weight (lbs.)

Model	Near Cond.
4514	1185
5014	1533
6014	1863

DynaFlame Near-Condensing (DFX)

Model	Vent Diameter Inches			
	Outdoor	Cat IV Up to 50 ft	Cat IV Up to 100 ft	Cat II
4514	10	10	14	12
5014	10	10	14	12
6014	12	12	14	12

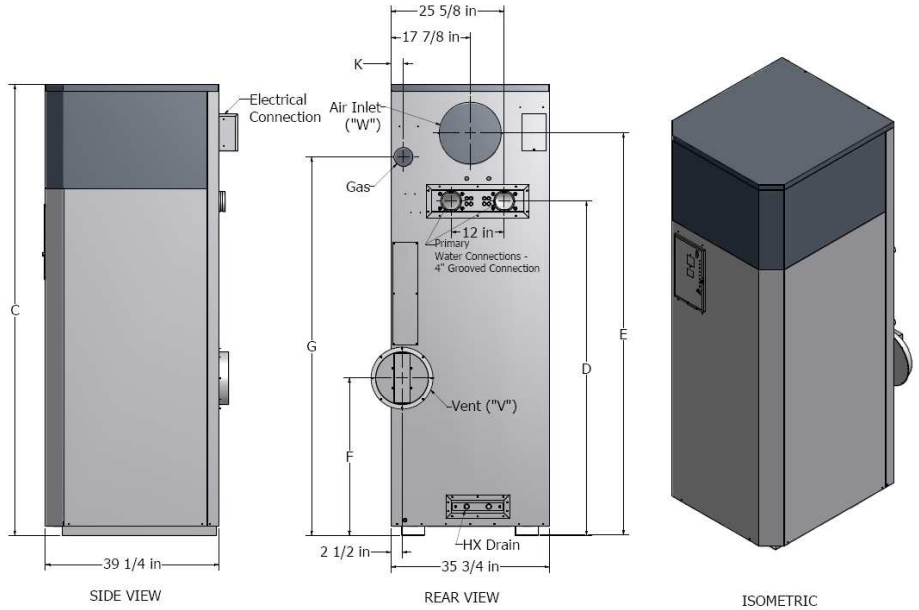

Dimensions and Specifications

Model	Height Dim. "C" (in.)	Water Conn. "D" (in.)	Air Inlet "E" (in.)	Flue Height "F" (in.)	Gas Height "G" (in.)	"H" (in.)	Air Inlet Dia. "W" (in.)	Water Conn. Prim. (in.) Grooved	Gas Conn. At Boiler (in.) NPT
4514	83	59 3/4	72 1/4	20 3/4	67 7/8	20 3/4	14	4	2 1/2
5014	88 1/4	65	77 1/4	26	72 1/4	34 1/2	14	4	2 1/2
6014	102	75 1/2	91	35 1/2	85 1/2	44 5/8	14	4	3

Current drawn by Boiler @ 230 Volts 60 Hz

Models	Amps	Phase
4514-5014	24	Single
6014	17.8	Three

Recovery Capacity

Model	100°F Rise		56°C Rise		80°F Rise		44°C Rise		60°F Rise		33°C Rise	
	GPH	LPH	GPH	LPH	GPH	LPH	GPH	LPH	GPH	LPH	GPH	LPH
4514	4746	17963	5932	22454	7910	29938						
5014	5273	19957	6591	24947	8788	33262						
6014	6290	23809	7863	29762	10484	39682						

Primary Heat Exchanger Head Loss & Flow

Model	Temperature Rise Across Heat Exchanger			
	30°F		35°F	
	USGPM	ΔP - Ft.	USGPM	ΔP - Ft.
4514	254.6	15.3	218.3	11.4
5014	283.0	19.6	242.5	14.9
6014	339.5	31.8	291.0	24.1

Model # _____ # Of Units _____ Type of Gas _____

Total Input _____ BTU/hr Flow _____ USGPM @ Allowable Pressure Drop _____ ft.

Total Output _____ BTU/hr Recovery Rate _____ USGPH @ _____ °F

Optional Accessories _____